



BRUKSANVISNING SV	7
KÄYTTÖOHJEET FI	17
BRUGSANVISNING DA....	27
BRUKSANVISNING NO ..	37
GEBRAUCHSANWEISUNG DE....	47
INSTRUCTIONS FOR USE EN....	58
MODE D'EMPLOI FR....	68
GEBRUIKSAANWIJZING NL....	78

STIGA PRIMO



8211-0027-80

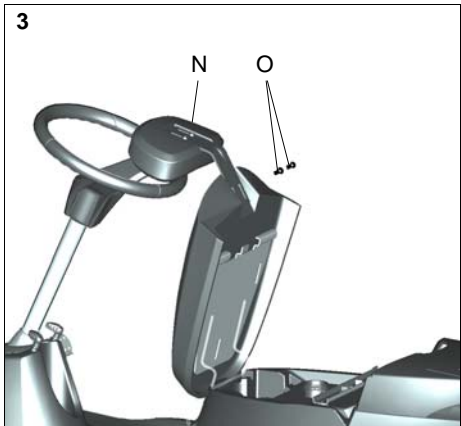
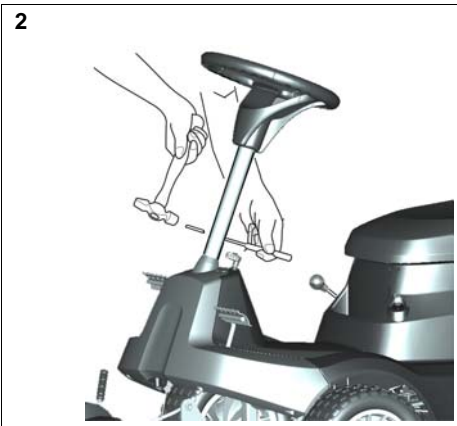
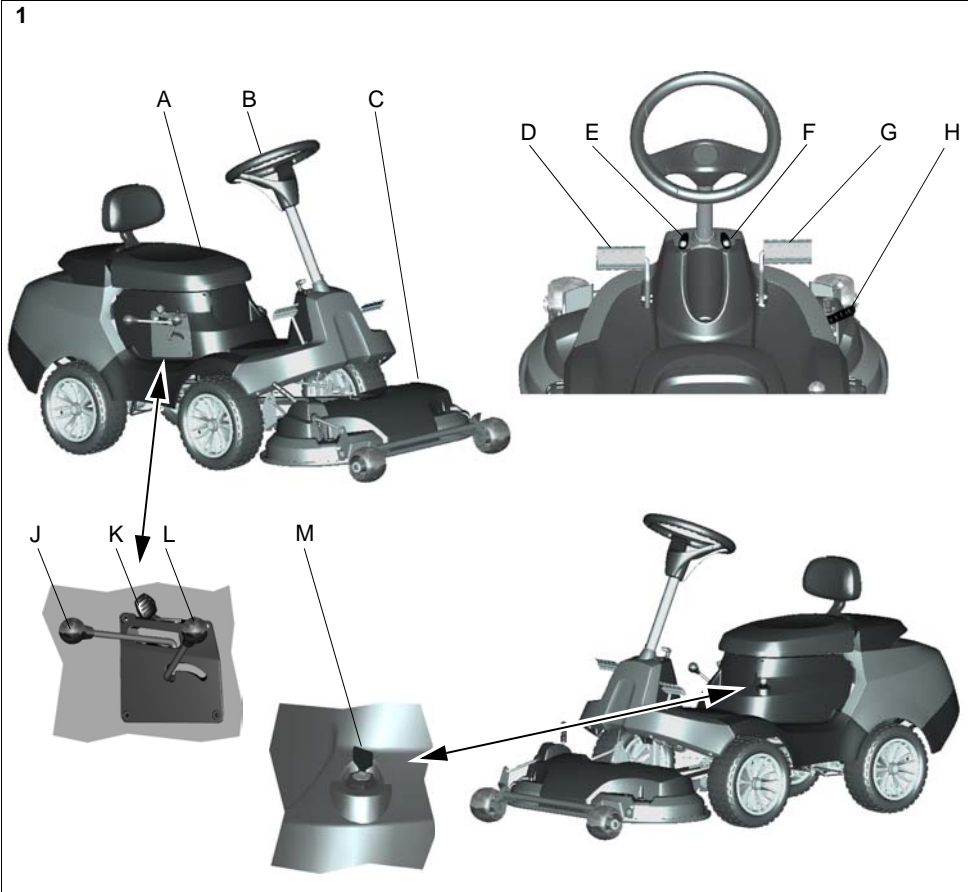

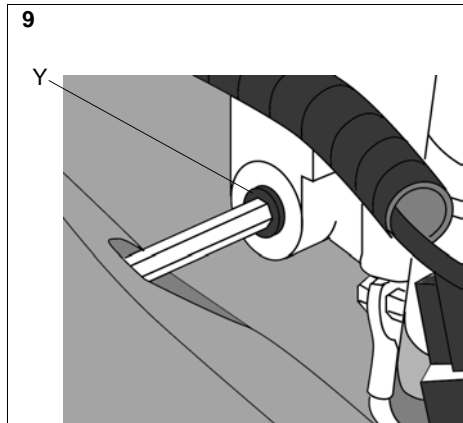
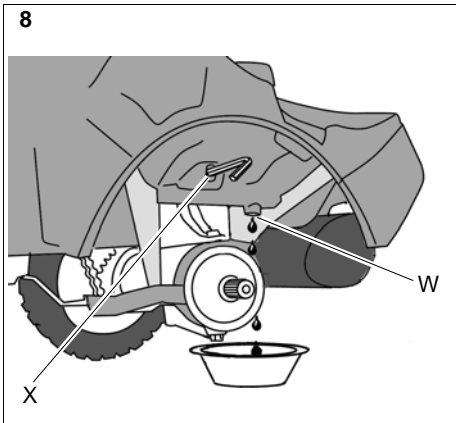
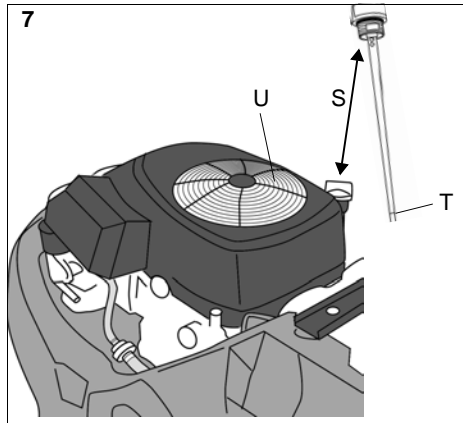
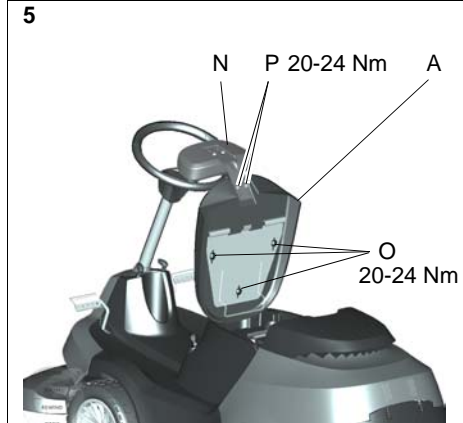
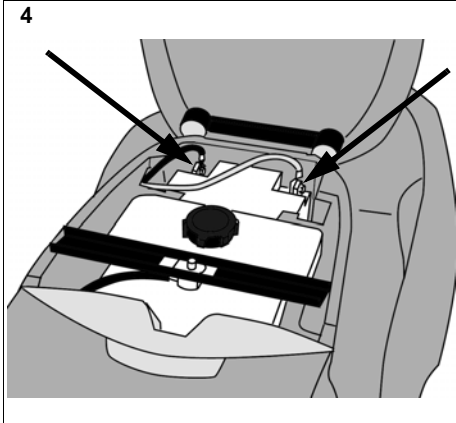

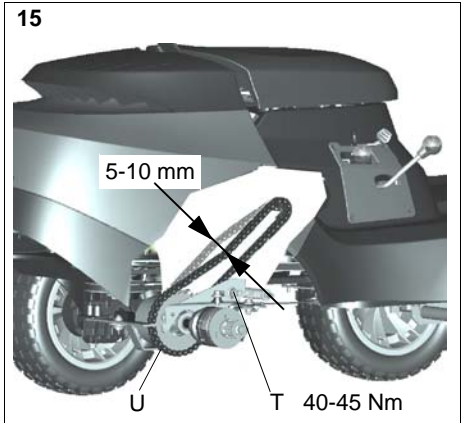
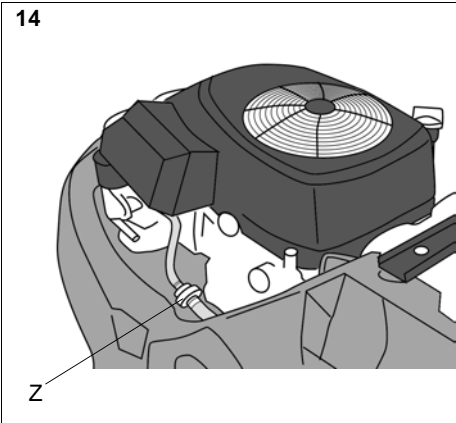
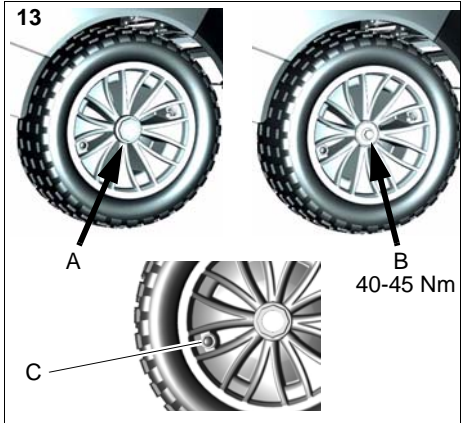
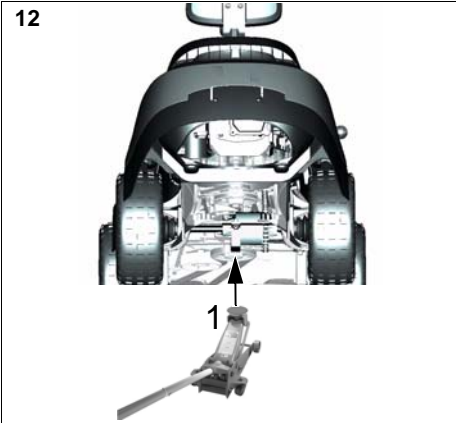
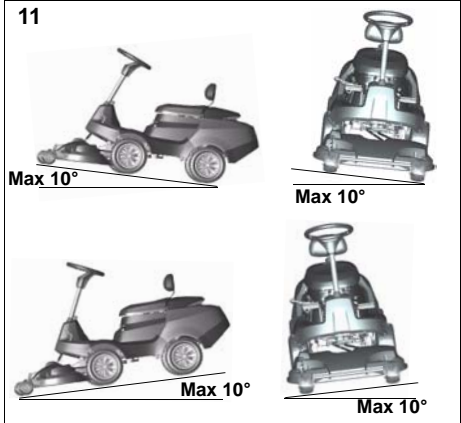
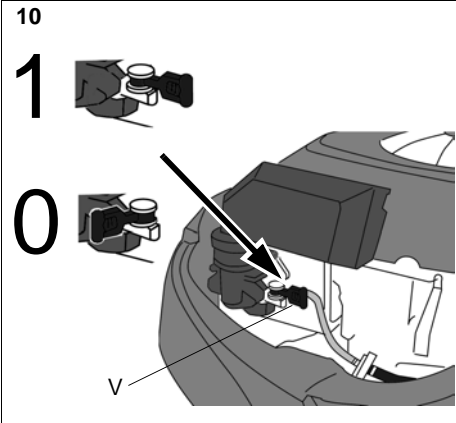

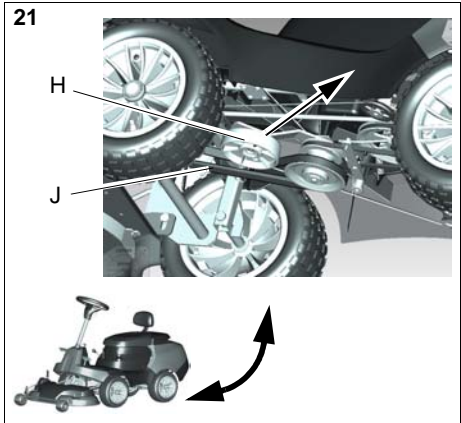
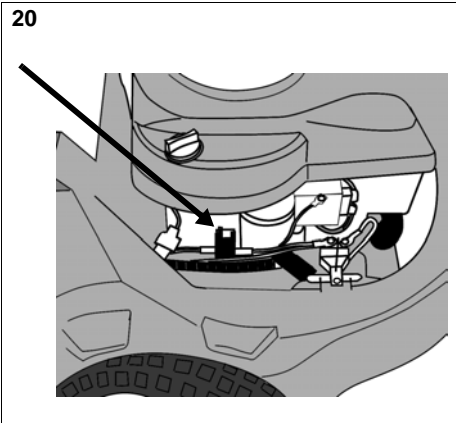
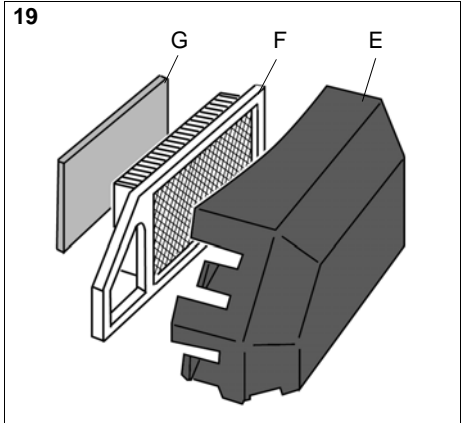
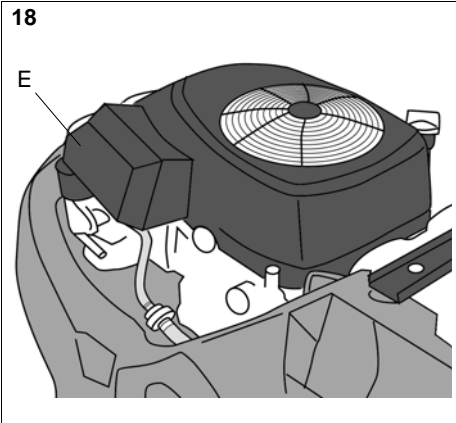
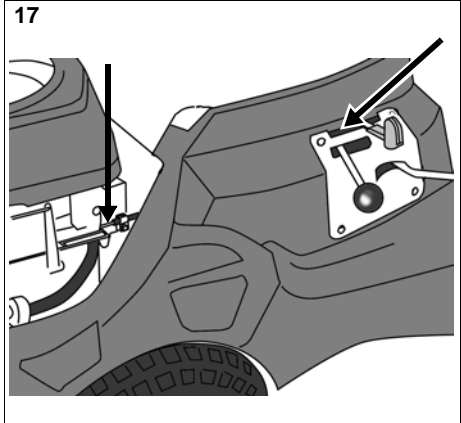
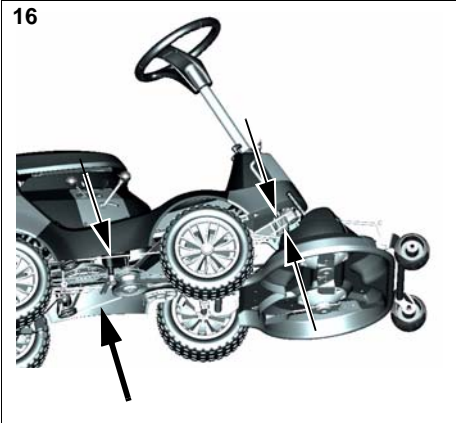

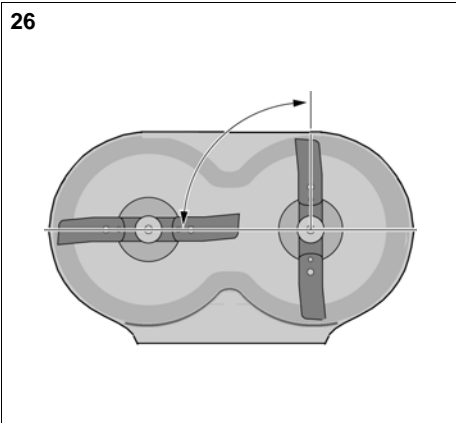
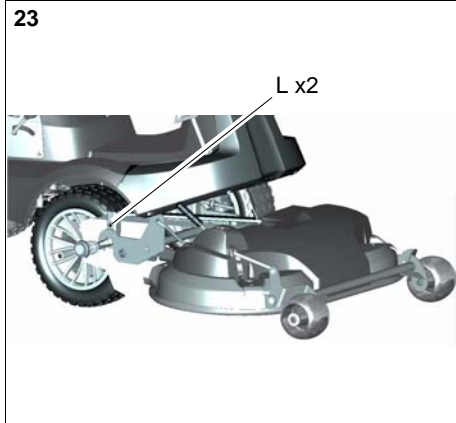
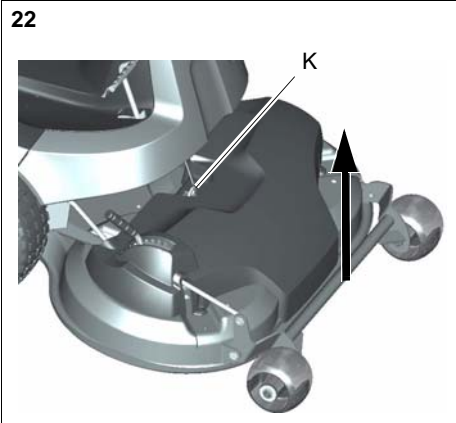

nance work described in this chapter must be followed according to the instructions and at the stated intervals.

This work should be carried out by an authorised workshop, but can also be carried out by the user. Service, carried out by authorised workshops, guarantees a professional job with original replacement parts.

We recommend taking the machine to an authorised workshop after each season before it is stored for the winter.

6.2 Preparation



Prevent the machine from rolling by always applying the parking brake.



Prevent unintentional starting of the engine by removing the ignition key.

All service and all maintenance must be carried out on a stationary machine with the engine switched off.

6.3 Raising



Jacks must only be placed in the designated area. Placing the jack in other locations will damage the machine.



The machine must only be raised on hard, stable and horizontal surfaces. Otherwise there is a risk of the machine dropping.



The machine must never be loaded with further weight when it is raised. Nobody must sit on the machine when it is raised.

For certain maintenance work, the rear part of the machine must be raised slightly so that the required rear wheel can be removed. Raise the machine as follows:

1. Position the machine on a hard, stable and horizontal surface.
2. Raise the machine using a jack, see fig. 12.

6.4 Wheels

For certain maintenance work, it is necessary to remove a rear wheel.

Dismantling:

1. Raise the machine according to 6.3.
2. Remove the cover disc (13:A).
3. Use a 17 mm wrench and remove the screw (13:B) with disc.
4. Pull the wheel from the axle.

Assembly:

1. Slide the wheel onto the axle.
2. Install the screw (13:B) with disc.
3. Tighten the screw to 40-45 Nm.

6.5 Tyre pressure

Adjust the air pressure in the tyres as follows:

Front: **1.2** bar (17 psi).

Rear: **1.2** bar (17 psi).

If the maximum tyre pressures are exceeded the safety valve (13:C) will be triggered. If this occurs, reset as follows:

1. Wait until the tyre has no pressure.
2. Press in the safety valve using a finger.
3. Fill with air to the specified pressure.

6.6 Changing engine oil

Change the engine oil for the first time after 5 hours of operation, and subsequently after every 50 hours of operation or once a season.

Change the oil more often (after 25 hours of operation or at least once a season) if the engine has to operate under demanding conditions or if the ambient temperature is high.

Use oil according to the table below.

Oil	SAE 10W-30
Grade	SJ or greater

Use oil without any additives.

Do not fill with too much oil. This can cause the engine to overheat.

Change oil when the engine is warm.



The engine oil may be very hot if it is drained off directly after the engine is shut off. So allow the engine to cool a few minutes before draining the oil.

6.6.1 Draining

1. Raise the machine so that the left rear wheel is raised a few cm above the ground. See 6.3.

If the machine is raised too much, oil cannot run freely in the chassis ducts whilst draining.

2. Remove the left-hand rear wheel. See 6.4.
3. Place a suitable container under the drain hole (8:W) in the machine's chassis.
4. Insert a 10 mm Allen key through the hole (8:X) in the chassis and unscrew the oil drain plug (9:Y) from the engine. Leave the oil drain plug in place on the Allen key inside the engine compartment.

Do not spill any oil on the drive belts.

5. Reinstall the oil drain plug (9:Y) once all the oil has been drained.
Tightening torque: 20 Nm.
6. Remove the dipstick (7:S) and fill with new oil.
Oil capacity: 1.2 litres.
7. Reinstall the dipstick (7:S).
8. Use a cloth or similar and wipe clean the oil duct in the chassis.

9. Reinstall the rear wheel and lower the machine. See 6.3 and 6.4.
10. Start the engine and run at idle for 30 seconds.
11. Check to see if there is any oil leakage.
12. Stop the engine. Wait for 30 seconds and then check the oil level. See 5.3.

Take the used oil, oily rags etc. to a recycling station.

6.7 Fuel filter (14:Z)

Replace the fuel each season.

Check that there is no fuel leakage once the new filter has been installed.

6.8 Deck belt (21:J)

After 5 hours of operation check that the machine's belts are intact and not damaged.

6.9 Adjusting the drive chain (15:U)

Check/adjust the belt tension each season as follows:

Check:

1. Raise the machine and remove the right-hand rear wheel. See 6.4.
2. The chain (15:U) must have 5-10 mm of play. Any required adjustment, see blow.

Adjustment:

Adjust the play by moving the tensioner wheel as follows:

1. Slacken off the nut (15:T) and set the tensioner wheel to the desired position.
2. Tighten the nut and check the play. Adjust again if required.
3. Tighten the nut to 40-45 Nm when adjustment has been completed.

6.10 Lubrication

All lubrication points according to the table below must be lubricated after every 25 operating hours as well as after each clean.

Item	Section below	Figure
Drive chain	6.10.1	15:U
Steering cable	6.10.2	16
Tensioning arms and moving joints	6.10.3	-
Throttle cable	6.10.4	17

6.10.1 Drive chain

Lubricate the drive chain (15:U) using chain spray as follows. Use universal type chain spray.

1. Trestle up the machine's right-hand rear wheel so that it can rotate freely. See 6.3.
2. Brush the chain clean using a wire brush.
3. Rotate the rear wheel by hand and at the same time spray the chain so that it is fully lubricated.
4. Lower the machine.

6.10.2 Steering cable

See fig. 16. Lubricate the steering cable using chain spray as below. Use universal type chain spray.

1. Brush the chain clean using a wire brush.
2. Turn the steering wheel and at the same time spray the cable so that it is fully lubricated.

6.10.3 Tensioning arms moving joints

Lubricate the bearing points using an oil can at the same time as activating the respective control.

Preferably carried out by two people.

Activate the controls:

- Steering
- Clutch, brake
- Raise the cutting deck
- Engaging the cutting deck.
- Setting the cutting height

6.10.4 Throttle cable

See fig. 17. Lubricate the cable ends using an oil can at the same time as activating the respective control.

6.11 Battery



Never overcharge the battery. Overcharging can damage the battery.



Do not short-circuit the battery's terminals. Sparks occur which can result in fire. Do not wear metal jewellery which can come into contact with the battery terminals.

In the event of damage to the battery casing, cover, terminals or interference to the strip covering the valves, the battery should be replaced.

The battery is a valve-regulated battery with 12 V nominal voltage. The battery fluid does not need to and cannot be checked or topped up. The only maintenance that is required is charging, for example after extended storage.



The battery must be fully charged before being used for the first time. The battery must always be stored fully charged. If the battery is stored while discharged, serious damage will occur.

6.11.1 Charging with the engine

The battery can also be charged using the engine's generator as follows:

1. Install the battery in the machine as shown below.
2. Place the machine outdoors or install an extraction device for the exhaust fumes.
3. Start the engine according to the instructions in the user guide.

4. Allow the engine to run continuously for 45 minutes.
5. Stop the engine. The battery will now be fully charged.

6.11.2 Charging using battery charger

When charging with the battery charger, a battery charger with continuous voltage must be used.

Contact your dealer to purchase a battery charger with constant voltage.

The battery can be damaged if a standard type battery charger is used.

6.11.3 Removal/Installation

The battery is placed under the seat. See fig. 4. During removal/installation of the battery, the following applies regarding connection of the cables:

- During removal. First disconnect the black cable from the battery's negative terminal (-). Then disconnect the red cable from the battery's positive terminal (-).
- During installation. First connect the red cable to the battery's positive terminal (+). Then connect the black cable to the battery's negative terminal (-).



If the cables are disconnected/connected in the wrong order, there is a risk of a short-circuit and damage to the battery.



If the cables are interchanged, the generator and the battery will be damaged.



Tighten the cables securely. Loose cables can cause a fire.



The engine must never be driven with the battery disconnected. There is a risk of serious damage to the generator and the electrical system.

6.11.4 Cleaning

If the battery terminals are coated with oxide, they should be cleaned. Clean the battery terminals with a wire brush and grease them using terminal grease.

6.12 Air filter

The pre-filter (foam filter) (19:G) must be cleaned/replaced every 25 operating hours.

The pre-filter (paper filter) (19:F) must be cleaned/replaced every 100 operating hours.

NOTE! Clean/replace the filter more often if the machine operates in dusty conditions.

Remove/install the air filters as follows.

1. Clean carefully around the air filter housing (18:E).
2. Remove the air filter cover by removing releasing the two clamps at the rear edge of the cover.

3. Remove the filters. The pre-filter is located far in towards the engine. Make sure that no dirt gets into the carburettor. Clean the air filter housing.
4. Clean the paper filter by gently tapping it against a flat surface. If the filter is very dirty, change it.
5. Clean the pre-filter. If the filter is very dirty, change it.
6. Assemble in reverse order.

Do not use compressed air or petroleum based solvents such as kerosene to clean the paper filter insert. This will damage the filter.

The paper filter insert must not be oiled.

6.13 Spark plug

The spark plug(s) must be replaced after 200 hours of operation.

Before disconnecting the spark plug, clean around its mounting.

Spark plug: Champion RC12YC or equivalent.

Electrode distance: 0.75 mm.

6.14 Engine's cooling air intake (7:0)

The engine is air-cooled. A blocked cooling system can damage the engine. Clean the engine's cooling air intake every 50 operating hours. A more thorough clean of the cooling system is carried out at each basic service.

6.15 Fuse

In the event of electrical faults, check/replace the fuse, 20 A. See fig. 20.

If the fault persists, contact an authorised workshop for repair.

6.16 Cutting deck

6.16.1 Safety

To reduce the risk of accidental injury in the event of a collision and to protect important parts in the cutting deck, a force limiter is integrated as follows.

- Shear bolts between blades and blade bar.
- Torque limiting between gear wheels and blade shaft.
- Possibility of positive drive belt slipping on the plastic gear wheels.

6.16.2 Dismantling

It is easier to carry out certain maintenance work if the cutting deck is removed from the machine. Remove the cutting deck as follows:

1. Set the maximum cutting height.

2. Pull out the belt idler (21:H) and push the belt (21:J) down by the side of the belt idler to release the belt tension.
3. Force the belt off the machine's pulley.
4. Raise the deck and unhook the lift cable's spring (22:K).
5. Remove the locking screws (23:L) from both sides.
6. Unhook the deck from the front axles and move the deck forward. See fig. 24.

6.16.3 Assembly

Install the cutting deck as follows:

1. Hook the deck over the front axles. See fig. 24.
2. Install the locking screws (23:L) on both sides.
3. Set the maximum cutting height.
4. Raise the deck and hook on the lift cable (22:K).
5. Install the belt (21:J) onto the pulley.
6. Pull out the belt idler (21:H) and place it on the outside of the belt so that the belt tensions.

6.16.4 Replacing blades



Wear protective gloves when changing blade(s) to avoid cutting yourself.

Check that the blades are always sharp. This produces the best cutting results. The blades should be replaced once a year.

Always check the blade(s) after a collision. If the blade system has been damaged, defective parts should be replaced.



Always use genuine spare parts. Non-genuine spare parts can entail a risk of injury, even if they fit the machine.

The blades are replaceable. When replacing, both blades on the same blade bar must be replaced to avoid imbalance.

Attention!

Note the following when reassembling:

- The blades and blade bar must be installed as in fig 25.
- The blades can be turned 1/3 of a turn in their mountings. Select positions so that the blades are offset 90° from each other. See "6.16.5" below.

Tightening torque:

Screws (25:P) - 45 Nm

Shear bolts (25:Q) - 9.8 Nm

In the event of a collision, the shear bolts (18:Q) can break and the blades bend back. If this has happened, install genuine shear bolts and tighten as above.

6.16.5 Synchronising, blades

The deck has synchronised blades.

If one of the blades has struck a solid object (e.g. a stone), the synchronisation may be altered. This entails a risk of the blades colliding with each other.

Correctly synchronised blades must be offset 90° from each other. See fig. 26.

Always check synchronisation after a collision.

If the blades are not synchronised, one or more of the following faults may have occurred in the cutting deck:

- The positive drive belt has slipped on the gear wheels.
- Torque limiting between gear wheels and blade shaft has deployed. The arrows in fig. 27 must be opposite each other for an intact deck. When torque limiting has deployed, the arrows are **not** opposite each other.
- The blade member is incorrectly installed on the blade shaft. Can be installed in three different positions. See 25:R.

In the event of incorrect synchronisation according to the two first alternatives, contact an authorised workshop for repair.

6.16.6 Cleaning

The underside of the deck must be cleaned after each use.

Set the highest cutting height and set the deck in the transport position. Cleaning is facilitated if the machine's front wheels are driven up onto a couple of planks or similar.

Clean the underside of the deck carefully. Use water and a brush.

When the surfaces are completely dry and clean, touch up the paintwork. Use durable paint intended for metal outdoors.

7 PATENT - DESIGN REGISTRATION

This machine or parts thereof is covered by the following patent and design registration:

SE 97 0427 & DE M97 07 997.9, EG 000503107-0001 & -0002.

GGP reserves the right to make alterations to the product without prior notification.